



Instructions for use  
Digital ARCA In-the-Ear hearing instrument

A14

A34

A44

*Beltone*™ ARCA



## **A new Beltone hearing instrument**

Congratulations on your choice of a Beltone hearing instrument. This is an important step towards clearer hearing and better understanding. We have used all our experience with hearing instruments to help you communicate, lead an enjoyable social life and listen to the world around you.

Your hearing instrument is a very advanced device. Your hearing care practitioner has tuned it to your individual needs. With a little devotion and patience you will become familiar with it.

This booklet is a short guide to assist you in getting acquainted with your hearing instrument. Read it carefully and use it as a guideline.

We wish you happiness and pleasant listening with your new instrument.

Beltone

## **This booklet & your instrument**

In this booklet you will find explanations on controlling your instrument, on the daily handling of it, and on its use. Furthermore, you can read what to do if things do not live up to your expectations. We will also give a few practical steps towards better hearing.

### **Contents**

Switching on and off	4
Changing batteries	5-6
Inserting and removing the instrument	7-9
Setting the volume (optional)	10
Program switch (optional)	11
T-program (optional)	13-15
Maintenance and cleaning	16-23
Solving small problems	24-25
Eight steps towards better hearing	26-29
International warranty and service	30
Technical Specifications	30
General Precautions	32

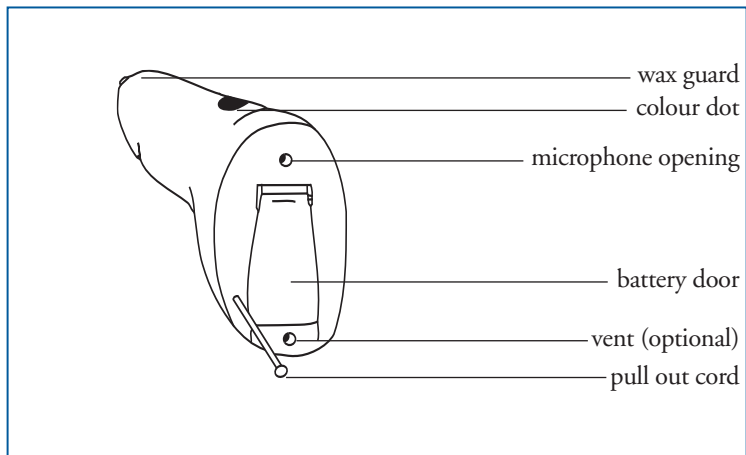

A14 CIC hearing instrument

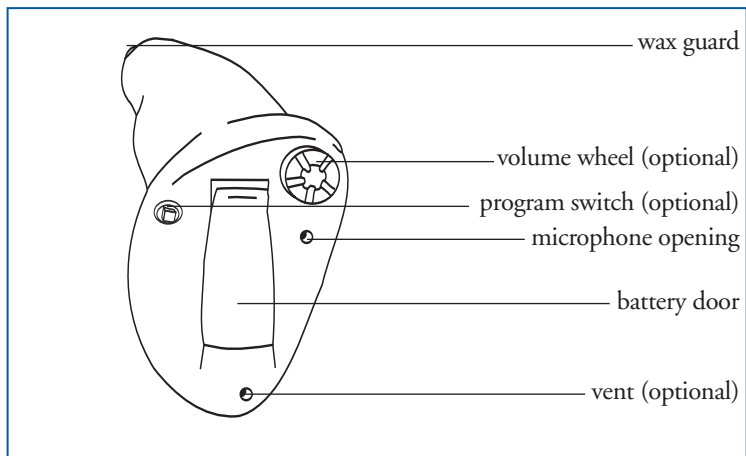

2 A34 ITC hearing instrument

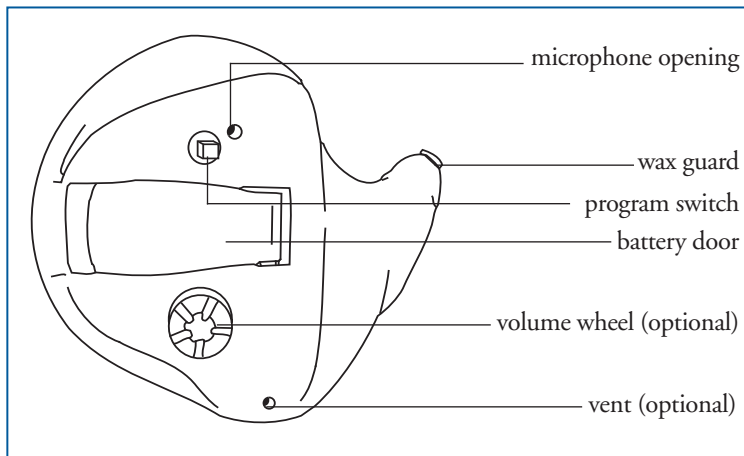

A44 ITE hearing instrument

## Switching on and off

Your hearing instrument is switched off by opening the battery door.

Switch your instrument on by closing the battery door.

Alternatively, if your hearing instrument is equipped with a volume control, you can switch it on and off by turning the volume wheel past a perceptible resistance.

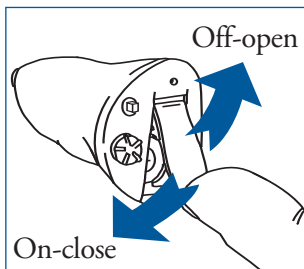

If your device is equipped with a multi-program switch, at start up you will hear one beep if the instrument is set on program 1. If it is set on program 2 you will hear two beeps.

- At night, leave the battery door open. It increases battery life and allows moisture in your instrument to evaporate and boosts the instrument's life span.

## Changing batteries.

When the hearing instrument generates a warning signal it's advisable to change your battery as soon as possible. The signal will continue as long as the battery is not changed or unless it does not run out of power, and therefore it is advisable to keep an extra battery at hand.

Open the battery door by placing your fingernail or a pencil under the edge of the battery door and gently push it backwards. When opened, remove the dead battery. The end of the cleaning brush is magnetic. It allows for easy battery removal/insertion.

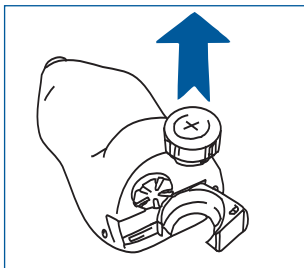
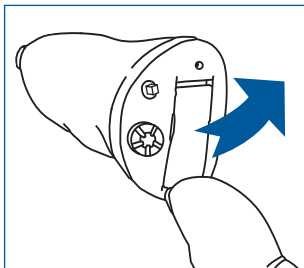

The replacement battery type and size depends on your hearing instrument:

<u>Instrument type</u>	<u>Battery type</u>
CIC — A14	10 A zinc-air
ITC — A34	312 zinc-air
ITE — A44	13 zinc-air

Remove the protective seal from the fresh battery and insert it in the battery door, with the plus side facing up. You will recognize the plus side of the battery because it is marked with a +. Check whether the + symbols on the battery and on the battery door are on the same side.

Always insert a battery in the opened door, never directly into the instrument.

Close the battery door. This should go smoothly, so never force it as this could damage your instrument.

## Warnings

- Keep batteries away from children and mentally challenged persons.
- Batteries can be harmful if swallowed. If you do, seek medical attention immediately.
- Do not attempt to recharge the batteries, as they could explode.
- Do not burn the batteries, as they could explode.
- Replace spent batteries and do not leave them in the instrument for a prolonged period.
- Used batteries are harmful to the environment. Please dispose of them according to local regulations or return them to your hearing care practitioner.

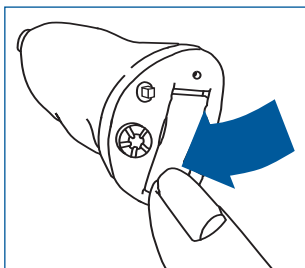
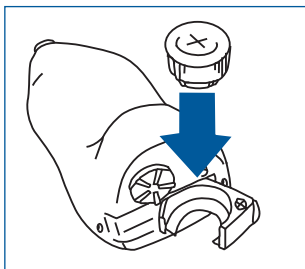

# Inserting and removing the instrument

## Inserting

- The insertion process varies with the shape of your ear canal. A fairly straight ear canal allows easy insertion. However, some ear canals have sharper curves and may require more care.

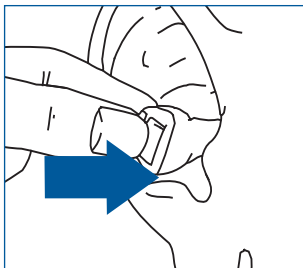

- Take the hearing instrument between thumb and index finger and position its 'point' in your ear canal. The colour dot must point upwards on CIC instruments of type A14.

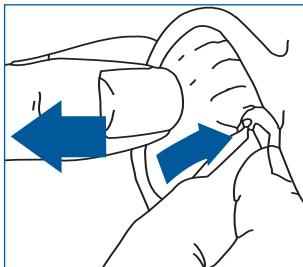

- Now slide the instrument all the way into your ear canal with a gentle, twisting motion. Insertion can be easier if you gently pull your auricle backward with your other hand.

- Move the instrument up and down with your index finger and press gently to ensure it is positioned correctly. Opening and closing your mouth can aid insertion. You will feel when the instrument is inserted correctly.

- If your hearing instrument is equipped with a volume control, you can insert the device in your ear canal with the volume turned off (cf. page 4). Once inserted, switch the instrument back to on by turning the volume wheel. This will avoid feedback problems.

## Removing your instrument

- Using your thumb and index finger gently pull the hearing instrument (not the battery door) from your ear. CIC instruments of type A14 have a thin plastic pullout cord. Use this. Never pull the battery door.

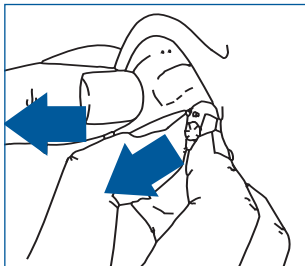

- Removal may be easier if you open and close your mouth while simultaneously pulling your auricle backward with your other hand.

Take some time at home to practice how to insert and remove your instrument. Work conveniently positioning your elbows on a table and maybe using a mirror.

## Recognising left and right instruments

Your hearing instrument is custom-made to fit your ear. Therefore, right and left instruments differ in shape.

Your hearing instrument is marked with either a left or right indication:

- A left instrument has a blue wax guard or blue dot;
- A right instrument has a red wax guard or red dot.

This is easy to remember: **Red = Right**.

The colour dot must point upwards on the CIC instruments of type A14.

Do not swap your hearing instruments. Please pay attention to this during cleaning, storing, and inserting.

## Setting the volume (optional)

Your instrument has a fully automatic volume control. Therefore, it should not be necessary to control the volume (loudness) manually. However, ITC instruments of type A34 and ITE instruments of type A44 can be equipped with a manual volume control as well. Use it to set the most comfortable volume level. Utilize your index finger to turn the volume wheel. Turn the wheel forward to increase and turn it backward to decrease the volume.

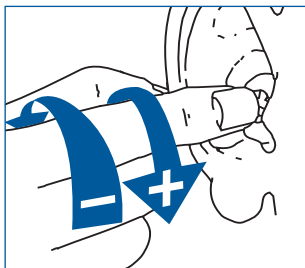

You can as well employ the volume control to switch on and off your instrument if turning the wheel past a perceptible resistance.

## Program switch (optional)

Your hearing instrument can be equipped with a switch that gives you access to two different listening programs. Each program will have the most suitable settings for certain situations.

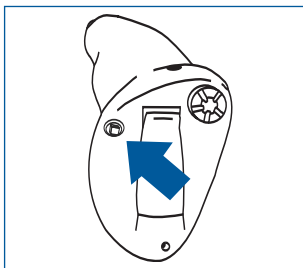

Through the switch, activating program 1 you will hear one beep tone, while the beeps will be two if activating program 2.

Note: -This is not available for CIC (A14) hearing instruments.

Let your hearing care practitioner fill out the following table:

Program number	Type of program	Intended for listening situations
1		
2		



## **T-program (optional)**

Your ITC instrument (A34) or ITE instrument (A44) may have a built in function, the telecoil, enabling in many cases an improved use of the telephone and better hearing in those churches or halls where an induction loop system is installed. In order to activate this function, the telecoil program has to be selected. In this program you will hear no sounds from the microphone, therefore most environmental sounds will be lost.

## Using the telephone

- Switch your instrument to the telecoil program.
- Hold your telephone handset behind your ear, close to the hearing instrument (1 inch, or 2-3 cm.) and slightly tilt the receiver outwards.
- Listen to the dialing tone and move the handset a little to find the position that give the best reception.
- If needed, and if your hearing instrument has it, turn the volume wheel up or down.
- After completing the phone call, switch your instrument back to the microphone program.

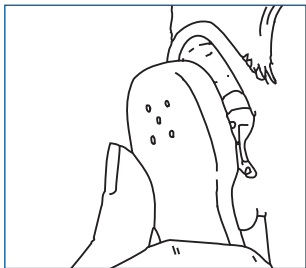

If the phone used has poor telecoil signal, use the microphone program. Do not hold the handset too tightly against your ear since this might cause “whistling”

## Hearing through an induction loop

More and more public places, churches, theatres and cinemas, have induction loop systems. In these particular rooms, they transmit, wirelessly, the sound of the presenter or show. At home, radio or television can be connected to an induction loop. Sound quality through an induction loop is often better because noises from the environment are not transmitted.

- Switch your instrument to the T-program, using the program button.
- Choose a good spot. Reception is not clear at all locations; it depends on the position of the induction loop. Watch for signs or try a different seat yourself.
- When available, and if needed, adjust the volume control up or down.
- After the end of the service or show, switch your instrument back to the microphone program. You will now hear through the microphone again.
- If the sound of your hearing instrument in the T-program is very soft all the time, ask your hearing care practitioner to make an adjustment.
- Your hearing care practitioner will gladly provide you with advice regarding an induction loop system at home. Ask for it.

## Maintenance and cleaning

Earwax (cerumen) will accumulate on your hearing instrument during use. If earwax enters the instrument it can damage it. The instrument has a protection system, the wax guard. Clean the instrument and replace the wax guard filter regularly. Failure to do so can lead to an accumulation of earwax impairing sound quality.

Cleaning is easier when accumulated earwax is dry; e.g., in the morning, before you insert the instrument into your ear.

### Cleaning the instrument

- Clean your instrument with a soft, dry cloth and the small brush. Do this above a soft surface or table to avoid damage if the instrument falls.
- Do not use water or fluids.

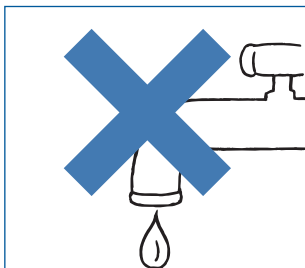
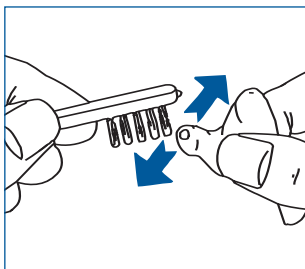

## Cleaning the vent

Your hearing instrument may have a vent, a small canal through the entire instrument. If so, clean it regularly.

- Insert the vent-cleaning tool – plastic line with handle – into the vent. Push the cleaning line completely through the vent.
- Wipe off any collected earwax.
- Pull the line out and wipe off again.
- Repeat this until all the earwax has been removed.

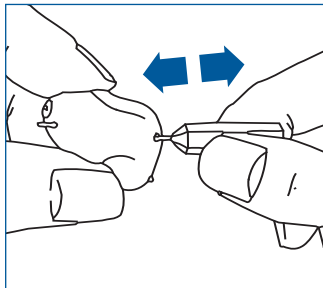

## Wax guard

Your hearing instrument is usually equipped with a wax guard system. This prevents earwax entering the instrument. Replace the wax guard every two weeks or sooner, depending on earwax accumulation.

Beltone uses two different wax guard systems, depending on the size and type of the hearing instrument. They are described on the following pages.

- Work at a table. It is easier and avoids your instrument falling onto the floor or items getting lost.

## Replace wax guard 'Sentry II'

Hearing instruments of type CIC (A14) are usually equipped with a wax guard called "Sentry II". Please verify this with your hearing care practitioner.

Sentry II wax guards are available in a set, containing red guards, blue guards, and a dedicated tool for changing them.

Use red wax guards for right instruments and blue guards for left instruments.

- To remove the wax guard from your hearing instrument, slide the forked side of the tool under the wax guard and pull it upwards.

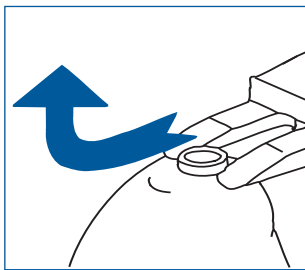

- Pick up a new wax guard from the front side of the card by using the other 'nub' end of the tool. The large red and blue arrows on the card indicate the front side. Slide the wax guard to the side, through the card.

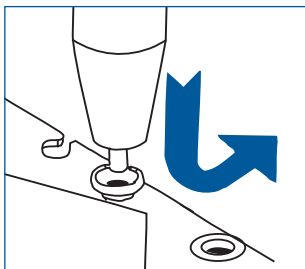

- Insert the wax guard into the sound outlet of the hearing instrument.

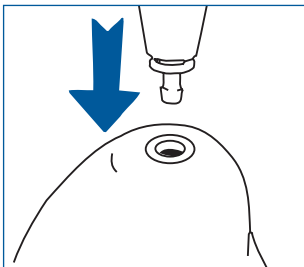

- Remove the tool and press the wax guard down with your thumb to secure it.

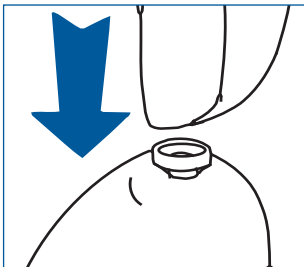

## Replace wax guard 'Sentry'

Hearing instruments of types ITC (A34) and ITE (A44) are usually equipped with wax guards called "Sentry". Please verify this with your hearing care practitioner.

Sentry wax guards are available in a small plastic box, containing red guards, blue guards, and a dedicated tool for changing them. Use red wax guards for right instruments and blue guards for left instruments.

The wax guard insertion tool has two different ends: A and B. End A is used to screw and unscrew wax guards; end B is used to tighten the guard in the instrument.

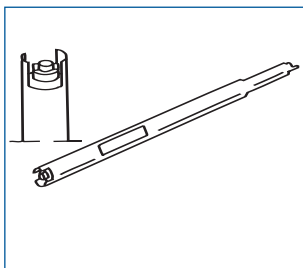

- Remove the wax guard from your hearing instrument using end A. Press the end firmly onto the wax guard and unscrew it. Turn counter clockwise.

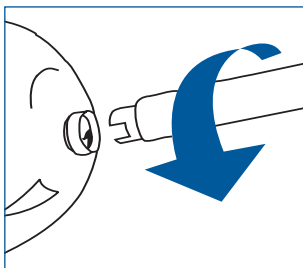

- Pick up a new wax guard from the box. Press end A firmly onto the new wax guard and unscrew it from the box. Turn counter clockwise.

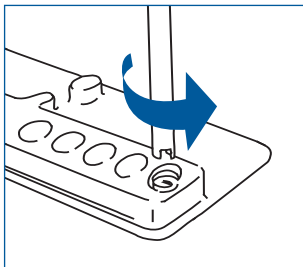

- Insert the wax guard into the sound outlet of the hearing instrument. Screw the guard into the hearing instrument. Turn clockwise.

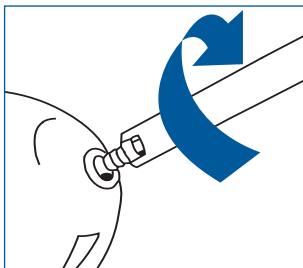

- Use the other end (B) of the tool to tighten (gently) the wax guard in the hearing instrument.

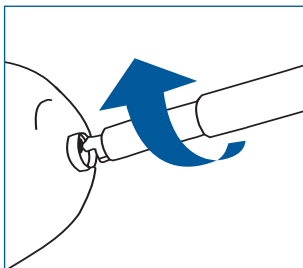

## **Storing your instrument**

When you are not using your instrument, keep or transport it in the box supplied. Leave the battery door open. Keep your instrument in a dry place, not in a bathroom or other humid place. Alternatively, you could store the instrument in a desiccator from your hearing care practitioner.

## **Cleaning the microphone opening**

Your instrument will not work properly if the microphone opening is dirty. Ask the hearing care practitioner to clean the opening. Never try this yourself.

## General warnings

- Do not leave your hearing instrument in the sun, near an open fire or in a hot, parked car.
- Do not wear your instrument while showering, swimming, in heavy rain or in a moist atmosphere such as steam bath or sauna.
- Should your instrument become moist, put it in a dessicator. Your hearing care practitioner will be happy to counsel on this.
- Remove your instrument when applying cosmetics, e.g. perfume, aftershave, hair spray, suntan lotion.
- Hearing instruments should be used only as prescribed by your hearing care practitioner. Incorrect use may result in sudden and permanent hearing loss.
- Do not allow others to use your hearing instrument. It may cause permanent damage.
- Hearing instruments usage by children or mentally challenged persons should be supervised at any time.
- Do not take your instrument into rooms where you receive treatment with X-rays or MRI.
- Wearing a hearing instrument might cause an increased production of earwax. In rare cases, the anti-allergenic materials may cause skin irritation. If so, or if in doubt, consult your physician or ENT consultant.

## Solving small problems

Your Beltone instrument is a reliable one. In case of minor problems

Symptom	Cause
<i>Feedback, 'whistling'</i>	Is your instrument inserted correctly?
	Is the volume very loud?
	Are you holding your hand or an object (e.g. a hat) too close to an instrument?
	Is you ear full of wax?
<i>No sound</i>	Is the instrument switched on?
	Is the instrument switched on the telecoil program?
	Is there a battery in the instrument?
	Is the battery still good?
	Is you ear full of wax?
<i>Sound is distorted, spluttering or weak</i>	Is the battery dead?
	Is the battery dirty?
	Did your instrument get moist?
<i>Battery drains very quickly</i>	Did you leave your hearing instrument switched on at night?
	Is the battery old?

or malfunctions, you may be able to solve them yourself.

Possible remedy	
	Put it in again
	Reduce it
	Move your hand away or create some more space between the instrument and the object
	Visit your physician
	Switch it on
	Switch it to the microphone program
	Insert a battery
	Replace it with a new one
	Visit your physician
	Replace it with a new one
	Clean it or use a new one
	Use a dessicator
	Always switch off the instrument at night
	Check the date on the battery packaging

## **Eight steps towards better hearing**

You need to get used to your new hearing instrument. Sounds seem new and different. That is because you grew accustomed to your diminished hearing. Therefore, familiar sounds seem strange or unnatural at first. Every first-time user of a hearing instrument responds differently to this. Some can wear the new instrument a whole day right from the start, while others find it hard to get used to.

After a while, you will notice you appreciate hearing with a hearing instrument and that you will find it quite normal. Below, eight steps are described that will guide you through the initial period. If you are not satisfied or keep experiencing problems, please consult your hearing care practitioner.

### **1. Get used to familiar sounds at home**

Try to get used to the new sounds from a familiar environment. Listen to the different (background) sounds and try to recognise them. When you are tired from listening, remove your instrument and pause for a while. Talk or read aloud for a while. In that way you will familiarise yourself with the sound of your own voice. Gradually, you will learn to use the instrument for longer and become more comfortable with it.

### **2. Listen outside; quiet & traffic**

Go outside to a quiet place, e.g., the park or woods. Listen to the environmental sounds. Do you recognise them?

Please be careful with sounds from heavy traffic at this stage of getting used to your instrument. Sometimes it sounds very loud. Try not to get frightened.

### **3. Have a conversation with a single person**

Use your instrument in conversation with one person, a family member or a friend. Move to a quiet spot. Explain that you are now wearing a hearing instrument. Ask the other person to talk normally. Look at your conversation partner. If your instrument is tuned to your requirements you will be able to communicate better than before.

### **4. Listen to radio or television**

Listen to the radio or television. Start with the news, then turn to another program. Ask a 'normal hearing' person to set the volume of your radio or television to a comfortable level. If necessary, adjust the volume on your hearing instrument.

If you cannot understand the radio or television, ask your hearing care practitioner to adjust your hearing instrument. He or she is able to inform you on other facilities, such as an induction loop system at home for your radio or television.

## **5. Get used to conversations in a group**

Following conversations in a group is often difficult because of the background noise. Listen to the different voices. Try to recognise them by timbre or rhythm and link each voice to a person. Focus your attention on the person you want to understand. Practice this regularly. If you did not understand something that was said, please ask for it to be repeated.

Ensure that you can see the face of your conversation partner(s) clearly and that there is sufficient light. This will help you to lip-read. Avoid 'looking into the light'. Position yourself with your back towards the window, so that you can see the other person(s) better. Ask others to talk slowly and clearly. Talking louder does not help.

## **6. Visit public buildings**

Visit public buildings. Try to sit near the speaker; try to be seated in the front rows in a show. Avoid a seat behind a pillar or in an alcove, you will be in a 'sound shadow.'

In a restaurant, sit with your back towards the wall. This avoids disturbing noises coming from behind you.

If an induction loop is present, and your instrument has a telecoil, use the T-program. However, not every position will have good sound reception. Watch for signs at the location or try a different seat.

## **7. Use your telephone**

Often, you can hear the telephone clearly with your hearing instrument in a microphone program. Hold the telephone handset 1-inch (2-3cm) from your ear and tilt the receiver outwards a little. See whether or not the telephone sounds better if you switch your hearing instrument to the T-program. Read about this on page 14.

Your hearing instrument meets strict international regulations. Therefore, it should be possible to use a GSM telephone in most cases. However, in some circumstances, disturbance might be audible through your hearing instrument.

## **8. Use your instrument all day**

Using your hearing instrument and practising with it is the best way to learn to hear again. Even if you can hear without an instrument in some cases. Try to wear your instrument all day. In that way, you will benefit the most.

Of course, a hearing instrument cannot restore natural hearing, but it will help you make the most of your hearing as it is today.

Go beyond these eight steps and discover the world of sound around you. Do the things you enjoy and listen to the sounds from your environment.

## International warranty and service

Any digital hearing instrument from Beltone has an international warranty. Read more on this subject on the warranty card you received with your instrument.

## Repairs

If your Beltone hearing instrument malfunctions, it must be repaired by a qualified technician. Do not attempt to open the case of the hearing instrument since this would invalidate the warranty. If your Beltone hearing instrument requires service, please contact your hearing care professional for assistance.

## Abroad

Before you leave, obtain from your hearing care practitioner an address list for Beltone services. In case you need support, contact the nearest Beltone Company during your stay abroad.

## Technical data for end-user

Max. Output dB SPL according to IEC-118-0	A14	119
Max. Output dB SPL according to IEC-118-0	A34	122
Max. Output dB SPL according to IEC-118-0	A44	125

# Hearing instrument identification

Your hearing care practitioner is:

---

---

---

Your name:

---

---

Your hearing instrument(s):

Model: Serial No. Right: #

Model: Serial No. Left: #

---

---

Serial number: Located on the outside

Year

Place of  
production

Serial number

## General Precautions

- Consult a physician if you find a foreign object in your ear canal, if you experience skin irritation or if excessive ear wax accumulates with the use of the hearing instrument.
- Different types of radiation, e.g. from NMR or CT scanners, may damage the hearing instrument. Therefore, do not wear the hearing instrument during these or other corresponding scanning procedures. Other types of radiation (burglary alarms, room surveillance systems, radio equipment, mobile telephones, etc) contain less energy and will not damage the hearing instrument. They could however momentarily affect the sound quality or create strange sounds from the hearing instruments.
- **Warning:** Do not wear the hearing instrument in mines or other explosive areas, unless those areas are certified for hearing instrument use.

CE  
0297

ARCA model A14-A34-A44

Faceplate/Electronics by Beltone A/S, Denmark

*Any issues relating to the EU Medical Device Directive 93/42  
/EEC should be directed to Beltone A/S, Denmark*

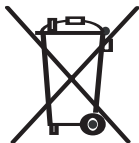

Please ask your local hearing care professional  
concerning disposal of your hearing instrument

Beltone A/S  
Mårkærvej 2A  
DK-2630 Taastrup  
Denmark  
Tel.: +45 72 11 11 11  
Fax: +45 72 11 11 88  
[www.beltone.biz](http://www.beltone.biz)

New address from June 1st 2006:

Beltone A/S  
Lautrupbjerg 7  
DK-2750 Ballerup  
Denmark

---

15315100 - GB - 05.11 - Rev. B

Printed in Denmark

© Beltone 2004